

TWD1744GE

17.26 liter, in-line 6 cylinder



TWD1744GE is a reliable, powerful and compact in-line 6 cylinder diesel engine. It's designed to power a wide range of stand-by and prime power generator sets.

This 17 liter diesel engine utilizes dual-stage turbochargers and heavy-duty steel pistons to provide excellent power density.

It features a proven combustion technology with Common Rail injection system, resulting in high fuel efficiency and low exhaust emission levels.

The engine also features a compact and low weight design that is well-balanced, providing smooth operation with low noise. It's designed for easily accessible service points.

A wide range of options are available, cooling package with the option of fixed or visco controlled fan and air-filter that will suit a variety of installations.

- High power density and fuel efficiency
- Low exhaust emissions
- Certified according to US EPA Tier 2 Stationary Emergency
- Compact and low weight design
- Dual speed 1500/1800 rpm
- Suitable for a wide range of applications
- Service interval 1000 hours

50 Hz / 1500 rpm

60 Hz / 1800 rpm

	Continuous power			Prime power			Standby power			Continuous power			Prime power			Standby power		
	kWm	kWe	kVA	kWm	kWe	kVA	kWm	kWe	kVA	kWm	kWe	kVA	kWm	kWe	kVA	kWm	kWe	kVA
TWD1744GE	532	500	625	645	606	758	710	667	834	563	529	661	682	641	801	750	705	881

Generator efficiency (typical): 94%

kWm = kiloWatt mechanical, net with fan*; kWe = kiloWatt electrical = kWm x Generator eff.; kVA = kiloVoltAmpere calculations based on a 0.8 power factor = kWe / 0.8

1 kW = 1 hp x 1.36; 1 hp = 1 kW x 0.7355

*) According to technical data

TWD1744GE

17.26 liter, in-line 6 cylinder

Technical Data

Configuration and no. of cylinders	in-line 6
Displacement, l (in ³)	17.26 (1053.3)
Method of operation	4-stroke
Bore, mm (in.)	149 (5.86)
Stroke, mm (in.)	165 (6.5)
Compression ratio	16.5:1
Wet weight, engine only, kg (lb).....	1900 (4190)
Wet weight, Genpac (engine, cooling system, air filtration system) kg (lb) ...	2200 (4851)

Fuel consumption

Prime Power, g/kWh (lb/hph)

	TWD1744GE	
	1500 rpm	1800 rpm
25%	211 (0.343)	225 (0.365)
50%	197 (0.319)	202 (0.328)
75%	194 (0.314)	197 (0.319)
100%	194 (0.314)	196 (0.318)

Standby Power, g/kWh (lb/hph)

	TWD1744GE	
	1500 rpm	1800 rpm
25%	208 (0.338)	222 (0.360)
50%	195 (0.317)	200 (0.325)
75%	195 (0.315)	196 (0.318)
100%	194 (0.315)	197 (0.319)

Dimensions

Not for installation. Dimensions in mm.

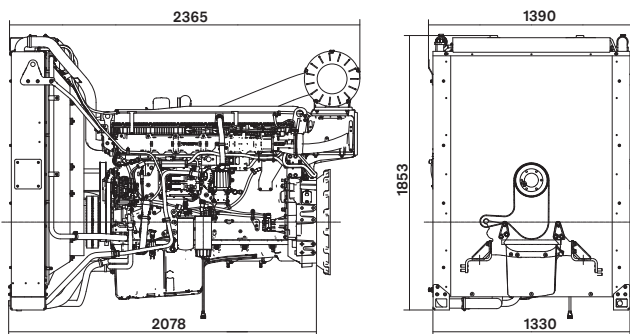

Technical description

Engine and block

- Wet, replaceable cylinder liners
- Steel pistons for high durability
- Crankshaft induction hardened bearing surfaces and fillets with seven main bearings
- Case hardened and Nitrocarburized transmission gears for heavy duty operation
- Viscous type crankshaft vibration dampers to withstand single bearing alternator torsional vibrations
- Replaceable valve guides and valve seats
- Overhead camshaft and 4 valves per cylinder
- SAE0 alternator interface

Lubrication system

- Full flow oil cooler
- Full flow disposable spin-on oil filter
- Bypass filter with extra high filtration
- Oil quality VDS4.5 10W30
- Engine delivered with oil

Fuel system

- Common Rail injection system
- Improved water separator and water-in-fuel sensor
- Improved fine fuel filtration efficiency with fuel pressure sensor
- F3 fuel injection system
- Improved filter capacity

Cooling system

- Efficient cooling with accurate coolant control through a water distribution duct in the cylinder block.
- Dual-circuit
- Belt driven coolant pumps (fixed or visco controlled fan drive) with high degree of efficiency
- Fixed or visco controlled fan drive
- Water-cooled charge air coolers
- Visco as option
- Coolant VCS2

Turbo charger

- Efficient and reliable dual stage turbo chargers
- Dual charge air coolers
- Waste gate system for the high pressure turbo charger

Electrical system

- ECM4, an electronically controlled processing system which optimizes engine performance. It also includes advanced facilities for diagnostics and fault tracing
- The instruments and controls connect to the engine via the CAN SAE J1939 interface
- Sensors for inputs such as: oil pressure, oil temp, boost pressure, boost temp, coolant temp, air filter pressure, water in fuel and fuel pressure.

Rating guidelines

PRIME POWER rating corresponds to ISO Standard Power for continuous operation. It is applicable for supplying electrical power at variable load for an unlimited number of hours instead of commercially purchased power. A10 % overload capability for governing purpose is available for this rating.

STAND-BY POWER rating corresponds to ISO Standard Fuel Stop Power. It is applicable for supplying stand-by electrical power at variable load in areas with well established electrical networks in the event of normal utility power failure. No overload capability is available for this rating.

Power standards

The engine performance corresponds to ISO 3046, BS 5514 and DIN 6271. The technical data applies to an engine without cooling fan and operating on a fuel with calorific value of 42.7 MJ / kg (18360 BTU/lb) and a density of 0.84 kg/liter (7.01 lb/US gal), also where this involves a deviation within 0 to +2% at rated ambient conditions at delivery. Ratings are based on ISO 8528. Engine speed governing in accordance with ISO 8528-5.

Please contact your local Volvo Penta dealer for further information. Please note that products illustrated may differ from production models. Not all models and accessories are available in all markets, and standard equipment may vary between different markets. Every effort has been made to ensure that facts and figures are correct at the time of publication. However, Volvo Penta reserves the right to make changes without prior notice at any time.

AB Volvo Penta

SE-405 08 Göteborg, Sweden
www.volvopenta.com